

A Socio-Political Application of Six Sigma:

The Study of the Cuban Transition

Jorge Luis Romeu, Ph.D.

<http://myprofile.cos.com/romeu>

Research Professor, Dept. Mech & Aerosp. Eng.
Syracuse University

romeu@cortland.edu

August of 2007

Introduction

President Fidel Castro, the Cuban octogenarian leader who has governed the country for the past 48 years, became seriously ill in July of 2006. He was provisionally substituted by his official successor, his 76 year old brother General Raul Castro, the Armed Forces Minister. A permanent power transfer will necessarily take place, for biological reasons, in a relatively short period of time. Such leadership change will not be swift or simple, given the half century of one-party government under the elder Castro. To avoid (8) a possible crisis, as well as to move the country toward a pluralistic system, it is imperative for the Cuban Nation to undertake an in-depth look at how things political will develop.

To help prepare conditions that favor a peaceful Transition in Cuba, we need to have a better understanding of the underlying problem. We approach this task following the best traditions of Cuba's great XIX Century statesman, Jose Antonio Saco. Such is the model used for this paper, as well as for our research work throughout all of our time in Exile.

Our professional background is in industrial and systems engineering, a field well-known for its studies to improve and/or optimize organizations. One of the modern tools in use for achieving process and organization improvement is the Six Sigma methodology (2). It was initially successfully used to solve industrial problems (3), and more recently health, government, and education (4) ones. In this paper we use the Six Sigma methodology in the systematic study of the problem of a peaceful Transition in Cuba: "quite unique" (5).

In the following pages we briefly overview Six Sigma and then apply its first two phases (Define and Measure) to analyze the problem of a Cuban Transition. We believe that, at the current stage of the problem and with the information available, such two phases are the only ones that can feasibly be implemented with some real basis.

Political Background

Four pre-conditions have been proposed by contemporary political scientists, to achieve a successful “reconstruction and stabilization” process. They have been thoroughly studied (6, 7) and even tried out in the recent Iraq and Afghanistan situations. They are:

1. Establishment of Personal Security (for citizens and former regime personnel)
2. Establishment of Law and Order (police, military and judicial areas)
3. Establishment of Critical Infrastructure (employment, healthcare, education)
4. Establishment of Effective Government (associations, unions, political parties)

These conditions should pursue, especially in the Cuban case, the establishment of a permanent, stable, independent and neutral political system; one that will pose no more, any security or international problem to the United States (US), as it occurred during the Cold War due to its alignment with the Soviet Union.

The purpose of the present study is, precisely, to use the Six Sigma methodology to find an efficient way to accomplish such goals.

Systems Engineering and Six Sigma

Systems engineering analyzes an entity, its parameters, its constraints and objectives, through operating conditions such as system bottlenecks and flows. It uses engineering tools and math to optimize (find the most efficient setting of) the entire operation.

Quality Engineering looks at a system’s operation via its inputs and outputs. It tackles its Sporadic Problems, which occur intermittently and randomly, and fixes them by Restoring the Status Quo. It also identifies and fixes its Chronic Problems, which are long term and permanent, by Changing the Status Quo. It does this by implementing four processes: Quality Assessment, which analyzes current status of the system; Quality Planning, which identifies issues for system improvement; Quality Improvement, which implements the improvements defined, and Quality Control, which assesses the system improvements and its steady-state implementations.

The Six Sigma methodology was first implemented in Motorola in the 1980s. Then, it was successfully extended by Hahn and Hoerl in GE, in the 1990s. The methodology is composed of five phases: Design, Measure, Analyze, Improve and Control, and is better known by its acronym: DMAIC.

When applying this methodology, we must start by defining and/or identifying what is (i) the entity of interest (here, the Cuban government and its opposition), what is (ii) the process to be modified (a Transition to a pluralistic system), and (iii) who is the ultimate customer who will benefit from the improvements obtained (the Cuban Nation).

In the rest of this paper we apply the first two phases of the Six Sigma methodology (i.e. Define and Measure), implementing some of the above-mentioned Quality Engineering tools. We then overview the remaining Six Sigma phases, summarizing future work.

The Define Phase

This is the first step in Six Sigma methodology. In it, we identify and define what is the real problem (Transition), what are its root causes, what are its key ingredients, whether there are reference cases, how have they appeared, what are their characteristics, what has been done right or wrong in previous similar cases, and what have they achieved.

Specifically for the Cuban Transition case, we want to know and/or define the Transition mission and objectives. We want to know why a Transition is needed; compare the cost of moving forward versus lack of change (remaining the same). Finally, we want to know what impacts will the Transition have on Cuba's different strategic partners (i.e. countries such as the US, European Union, Latin America, etc.) or in different system elements (the elderly, infants, and other weaker strata of the general population).

We also want to define the project team, including its composition (who participates) and functions (doing what); define the project components (what gets done and when) and its support team (who collaborates) and functions (and how); to establish the operational definitions (working procedures); define appropriate Performance Measures (PM), and define the cost of poor quality (how expensive is doing nothing, as opposed to change).

To identify key transition characteristics, we benchmarked (looked at examples of) past successful and unsuccessful XX Century transitions from long-lasting, authoritarian, personal regimes (i.e. *tyrants* in the Greek sense), where a strong man was backed by an organized military-political party machine, in several Ibero-American countries: Chile, Cuba, Brazil, Argentina, Spain, Portugal, Mexico, Venezuela, Paraguay, Central America and the Dominican Republic. We assessed a transition as a success, by analyzing the type of regime that followed it (i.e. if eventually it stabilized as a pluralistic, open regime).

We considered essentially Ibero-American countries, because of their resemblance with that of Cuba (i.e. a strong-man, backed by a strong political-military machine). Two exceptions are the Mexican (PRI) and Salvadorian authoritarian regimes, where the political-military machine created a succession mechanism, which periodically replaced the strong-man (i.e. President) but not the system itself.

Finally, and for the sake of completion, we also considered other well-known political transitions, from autocratic regimes in other parts of the world.

Some examples of successful Ibero-American transitions include:

- Spain, after Franco's death, in 1975.
- Portugal, after Salazar-Caetano, in 1973.
- Chile, after Pinochet's retirement, in 1989.

- Brazil, after the Generals retirement, in 1980.
- Mexico, after the PAN succeeded the PRI, in 2000.

Some examples of not so successful transitions include:

- Venezuela, after General Juan V. Gomez' death, in 1936.
- Brazil, after both of President Getulio Vargas' terms, in 1945 and 1954
- Argentina, after both of General Peron's terms, in 1955 and 1973
- Argentina, after the military dictatorship and the Malvinas war, in 1985
- Mexico, after General Porfirio Diaz' exodus, in 1911.
- Dominican Republic, after Rafael L. Trujillo's death, in 1961.
- Nicaragua, after the Somoza dynasty was overthrown, in 1979;
- Nicaragua, after the Sandinistas lost the elections, in 1990.
- Honduras, after General Carias Andino was deposed, in 1954.
- Guatemala, after General Jorge Ubico was deposed in 1944.
- El Salvador, after the military regime lost control, in 1979
- Haiti, after the Duvalier dynasty was overthrown,, in 1986,
- Cuba, after President Machado and the revolution of 1933.
- Cuba, after both of General Batista's exodus, in 1944 and 1959.
- Paraguay, after General Stroessner was overthrown, in 1989.

Some examples of transitions we considered, from other parts of the world are:

- Turkey, after Kamal Ataturk's death, in 1938
- China, after the death of Mao Tse Tung, in 1976
- Soviet Union, after Stalin's death, in 1953,
- Soviet Union, after the Brezhnev gerontocracy, in 1985
- Viet Nam, after the death of Ho Chi Minh, in 1969
- North Korea, after the death of Kim Il Sung, in 1994.

We synthesize below several key characteristics, fostering a successful Transition, which were deduced from analyzing and comparing these regime evolutions:

- Existing internal organizations
- Internal opposition cooperation
- Little intervention from abroad
- Some prior government opening
- Degree of internal peace and stability
- Environment for future economic growth
- Size and location of a country, regarding superpowers

Such conditions must exist, for a successful Cuban transition to take place. It is as much a historical responsibility for the Cuban government, to allow such conditions to develop, as it is also for the opposition, to have the talent to contribute to build them.

Measure Phase

This is the second step of Six Sigma. It was Lord Kelvin who said that “we do not really know anything about an entity that we cannot measure”. Hence, identifying/establishing good measurement variables and units is key, to assess progress and foster movement.

Several tools and activities contribute greatly to the establishment of good Baseline PM that, in turn contribute to implement an adequate measurement system. They include: Cause-effect diagrams (fishbone), Pareto charts and Checklists; Flowchart and process diagrams; Brainstorming and Affinity Analyses. With these activities we can plan and implement an effective data collection effort. This, in turn yields the measurements that Process Capability and Six Sigma procedures require, to assess the process.

Specific examples of activities of this phase include defining clear measurement systems to assess process objectives. In addition, detailed quantitative descriptions of the current state of affairs (e.g. production, consumption, socio-political, healthcare and education indices), for use as base line PM, are required. They serve to implement before vs. after comparisons and to measure process improvement. Some examples of these methods, in a Transition context, are given in the Appendix.

A detailed Transition Process Failure Mode and Effect Analysis (FMEA), describing what can fail, how, by what cause and with what consequences, is required. Also, cause-and-effect (Ishikawa) diagrams, describing how key factors impact Transition goals, are needed. Pareto charts, showing factor relative importance, are also necessary. All PM proposed to assess Transition success and progress should also include the reasons for their selection, as well as comparisons of present and projected values. See examples of FMEAs, Ishikawa and Pareto charts in the Appendix.

Transition PM are also meant to assess how this process actually fosters a more open society, politically and economically, as it moves forward (i.e. via a time series analysis). Below, we propose several variables to measure process progress, in time:

- Percent of government and private sector workers
- Percent population adhering to official and to independent organizations:
 - Clubs, unions, political associations, etc.
 - Civic and fraternal organizations, etc.
- Membership attendance to clubs, churches, libraries, lodges, etc.
- Percent GDP produced by both government and private sectors
- Number and Percent audience, of official and independent media
- Number of remaining political prisoners and exiles

Six Sigma and Quality Engineering methodologies also utilize QFD or Quality Function Deployment (also known as “House of Quality” or “the voice of the customer” who, in this case, is the Cuban Nation). QFD helps identify the “whats” (the customer desires). It also helps identify the “hows” (possible technical implementations). QFD also assesses

the association between problem variables, as well as provides measures (or ratings) for their *relative importance*.

The Appendix shows a “House of Quality” for the Cuban Transition problem. The Rows show the “whats” and columns show the “whys”. From the QFD analysis we identified several key variables and provided a set of “ratings” obtained by counting “hits” in rows and columns, and dividing by totals. There are several ways of producing a set of QFD ratings. In every case, the higher the ratings, the higher the variable importance. For the case in question, the ranking of customer desires given below:

- Political stability: 16.7%
- Establishment of a Civil Society: 14.8
- Economic Development/Reconciliation: 13%
- Political (Constitution and Parties): 11%
- Elections and the Judicial: 11%
- Media and Health/Education: 11%
- Labor and Business: 11%

The Three remaining Six Sigma Phases

The remaining phases, Analyze, Improve and Control, cannot be specified at this time. The Cuban Transition process has barely started (with President Castro’s illness, and substitution by his brother, General Raul Castro). It is still, too early to say.

However, and for the sake of completion, we overview the tasks required in each of the three remaining Six Sigma phases, providing implementation examples.

The Analyze Phase includes developing the data collection plan, the list of *theories* or hypotheses, the power and sample size required for testing them and the implementation of such hypothesis tests. In addition, the derivation of correlation and regression models, as well as models for analyses of variance (ANOVAs) and Design of Experiments (DoE) using the data collected in previous phases..

Specific examples of the above include building lists of factors to be assessed, analysis of root causes for failures and problems, and the estimations of Transition factor impacts, both on the Cuban population as well as on the main countries affected by it.

The Improve Phase includes developing creative (outside the box) problem solutions and benchmarking them (comparing them to those implemented by the above-mentioned Transitions). This will help strengthen the implementation of the Improvement strategies proposed. The Transition needs to consider several strategies and their associated costs and impacts, so that these may be compared, traded-off, so that the final, preferred and most efficient strategy (or combination thereof) is identified.

Strategy quantification, enables the creation of a sorted list of preferred courses of action and their respective impacts. Such impacts include the direct, indirect and collateral costs

of implementing the different strategies, and their socioeconomic and political impacts. Such costs allow defining counter-measures to help reduce negative impacts arising from some Transition decisions (e.g. the effect of higher prices on retirees). A Pilot plan with plausible results can then be constructed, including a working calendar.

The Control Phase includes the implementation of a process control plan, listing its required procedures, training and support, as well as the measurement and test plans to assess the improvements. Also needed are strategies for Transition stabilization, leading to the establishment of a permanent (political and economic) pluralistic society.

Finally, the Transition project final report, assessing its results, to verify that the proposed changes worked as intended, should also include a list of *lessons learned*. These should document the main problems occurred, their consequences, and their solutions.

Discussion

This research constitutes a “work in progress”, to be continued as events unfold and we acquire more information. Such task will constitute our research thrust for the following ASCE meetings, as well as for other Cuban forums, during the next few years.

However, results from the first two phases (Define and Measure) provide the basis for the rest of the work. It is imperative to establish appropriate initial conditions, in order for a Transition to take place (or take off) at all. Then, as the Transition develops, additional and more detailed specifications will be defined.

For, a Cuban Transition is not a Need; it is a Must! We suggest the following criteria, derived from our research about both Cuban history and successful political Transitions occurred in Ibero-America (8), to serve as reference points:

1. Transitions have evolved from the inside
2. Foreign pressures have proven negative
3. Cooperation between sectors is a must
4. National reconciliation is absolutely required
5. Assurance for all parts, requires of an Arbiter
6. But independent and non-partisan Arbiters
7. Possibly from Europe and Latin America.

Acknowledgements

Many friends and colleagues, in the Association for the Study of the Cuban Economy, ASCE, and the American Statistical Association, ASA, as well as elsewhere, have contributed to our research throughout the years. They are too numerous to be mentioned here, and we don't want to omit anyone. The original, more extended version of this research, containing in-depth historical and political digressions, was presented at the XVI ASCE Conference, in August of 2007, and is published in its proceedings.

Bibliography

1. Nueva Historia Minima de Mexico. El Colegio de Mexico. 4th Ed. (2007).
2. “Six Sigma”. Wikipedia: http://en.wikipedia.org/wiki/Six_Sigma
3. What is Six Sigma? P.S. Pande and L. Holpp. McGraw-Hill Professional. 2001.
4. A Different Look at Six Sigma. Quality Progress. Special Issue. January 2007.
5. G. Hahn and R. Hoerl’s comments; personal communication.
6. Planning and Assessing Stability Operations: a Proposed Value Focus Thinking Approach. G. D. Fensterer. MS Thesis. AFIT, Ohio. 2006.
7. Investigating the Complexities of Nation Building: a Sub-National Regional Perspective. M. J. D. Robbins. MS Thesis. AFIT. Ohio. 2005.
8. “The Spanish Caribbean and its Influence in a Transition in Cuba”. J. L. Romeu. ASCE Proceedings, 2005.

Appendices:

Example of QFD

Quality Function Deployment for Cuban Transition

	Constitution	Elections	Organizations	Pol. Parties	Armed Forces	Judicial Sys	The Media	Health/Educat	Industry/Comm	Count	Weight
Political Stability	X	X	X	X	X	X	X	X	X	9	0.167
Labor Policy		X	X	X		X		X	X	6	0.111
Economic Devel.	X	X		X		X	X	X	X	7	0.130
Social SafetyNet	X		X	X			X	X	X	6	0.111
Independence	X	X		X	X		X		X	6	0.111
Civil Society	X	X	X	X	X	X	X	X		8	0.148
Reconciliation	X	X	X	X	X	X	X			7	0.130
PersonalSecurity	X				X	X		X	X	5	0.093
Count	7	6	5	7	5	6	6	6	6	54	1.000
Weight	0.130	0.111	0.093	0.130	0.093	0.111	0.111	0.111	0.111	1.000	

Examples of Ibero American Transitions

Country	Origins	Changes	Took Over	Internal Oppos	External Forces
Spain75	Civil War	Death	Falanx	Cooperate	None
Portugal-73	Economic	African War	Military	NonExist	None
Chile-89	Economic	Referendum	Civilians	Cooperate	None
Brasil-80	Insurgency	Stability	Military	Cooperate	None
Mexico-00	Economic	Election	Opposition	Cooperate	None
Cuba-44	Revolution	Election	Civilians	Cooperate	None
Paraguay	Economic	Coup	Military	NonExist	Yes
Argentina55	Economic	Coup	Military	NonExist	Yes
Mexico-11	Civil War	Insurrection	Chaos	NonExist	Yes
Dom.Rep61	Occupation	Assassin	Military	NonExist	Yes
Cuba-33	Insurgency	Insurrection	Chaos	NonExist	Yes

Example of Transition Process Flowchart:

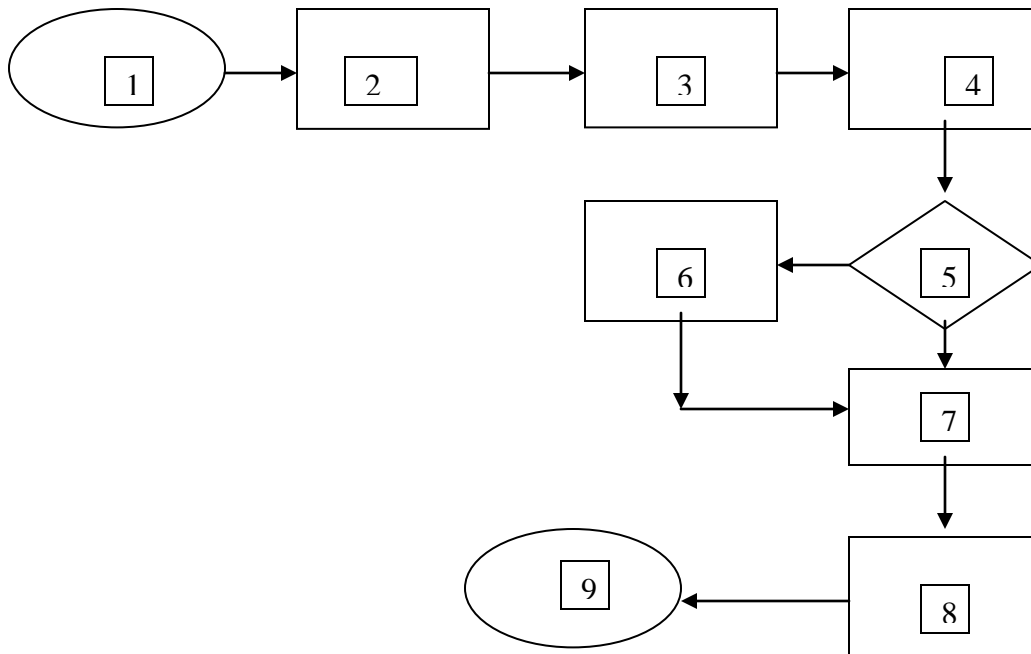

Flowchart Content:

1. Start
2. Initiate Contacts
3. Establish Working Groups
4. Seek Arbitrer
5. Is it/them acceptable to all?
 - a. Yes: Go to No. ^
 - b. No: Find causes, negotiate and Go back to No. 4
6. Specify each side's conditions
7. Are Conditions Acceptable?
 - a. Yes: Go to No. 8
 - b. No: Find causes, negotiate and Go back to No. 6
 - c. If stalemate; seek assistance from Arbitrer
8. Continue the process ...

Example of Transition Fault Tree Analysis

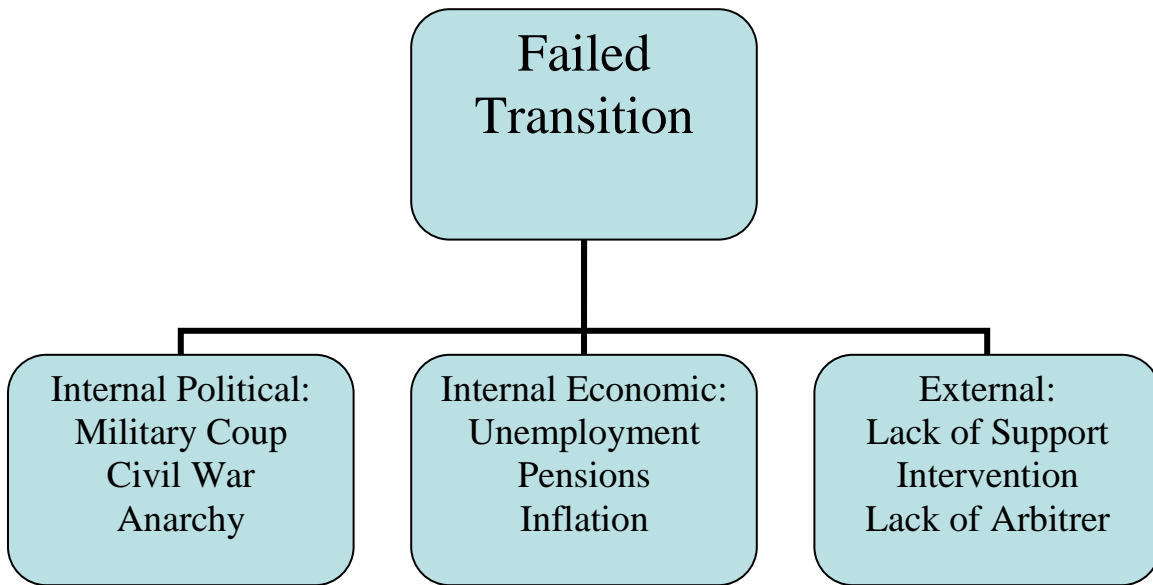

Example of Transition Cause and Effect (Ishikawa) Diagram:

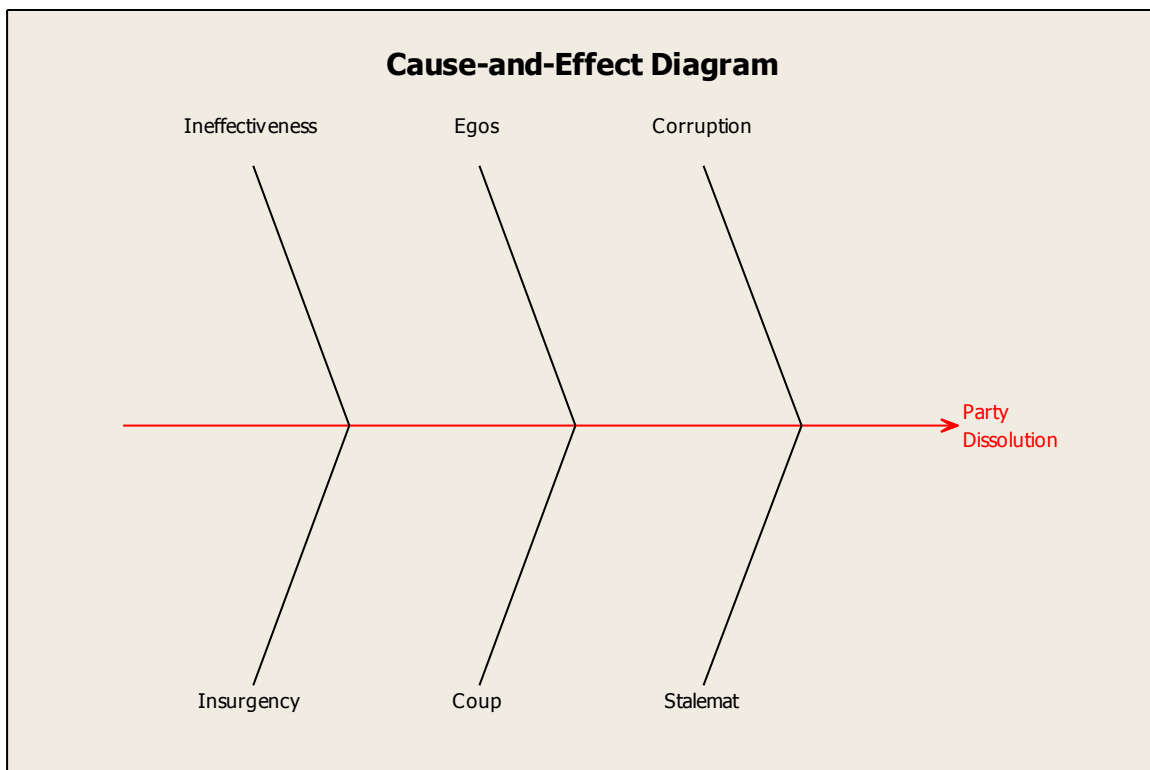

Example of Pareto Chart for Crucial Few Problems

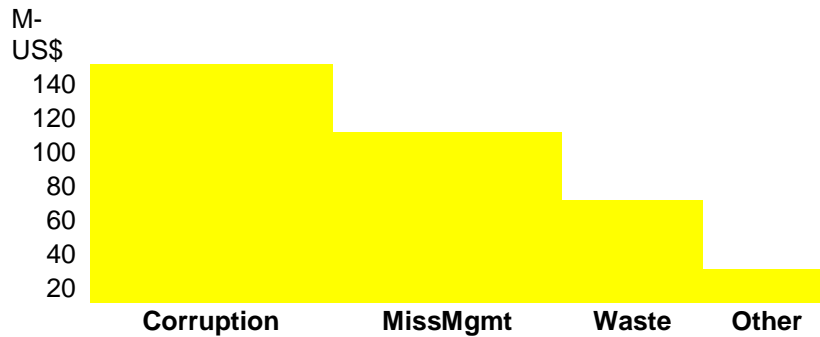

Example of Transition Process FRACAS or Failure Reporting and Criticality Analysis System:

1. Failure Observation: complaints about unemployment
2. Failure Verification: check statistics
3. Failure Isolation: identify specific problem area
4. Failure Removal: provide assistance to unemployed
5. Root Cause Analysis: what events have raised unemployment?
6. Corrective Action: try out economic and political adjustments
7. Effective? Is unemployment decreasing?
 - a. Yes: proceed to No. 8
 - b. No: go back to No. 6
8. Incorporate Correction
9. Go to No. 1

Example of Transition Failure Modes and Effects Analysis (FMEAs)

Example of Functional FMEA

Item	Function	FailMode	Causes	End-Effect	Detection	Compensation
Political	Seek	Discredit	Corruption	lawlessness	corruption	arbitrage
Organizats	Consensus	Splinter	Egos	apathy	stalemate	inspectors free
	Peacefully	Disband	Lack of \$	insurgency	media	press
		Barred	Coup	intervention	arrests	training
		Absorbed	Lack Ideas	civil war	violence	solidarity